

Pressure Drop Measurements on Distillation Columns

T.J. Cai, A. Shariat and M.R. Resetarits

Fractionation Research, Inc.

424 S. Squires St, Suite 200
Stillwater, OK 74074

Presented in the Distillation Symposium of the 2009 Spring AIChE Meeting

Tampa, Florida

April 27-29, 2009

Copyright© Fractionation Research, Inc.

UNPUBLISHED

The AIChE shall not be responsible for statements or opinions contained in its publications

ABSTRACT

Pressure drops are of major importance on distillation/absorption columns. This paper mainly discusses how to correctly measure, interpret and use pressure drop data. The possible causes of incorrect pressure drop measurements are studied including the effects of pressure tap dimensions, locations, and vapor condensation etc. The effect of the static head of vapor on pressure drop data and column pressures is evaluated. Variations of sectional pressure drops along the column are investigated based on the experimental data obtained from commercial size distillation columns at Fractionation Research, Inc. (FRI). For a packed column, it is found that the spacing between the liquid distributor and the top of the bed affects overall pressure drop measurements, which is confirmed by a fundamental fluid dynamics analysis.

Key Words: Distillation, tray, packing, pressure drop, hydraulics

*Corresponding author. E-mail: cai@fri.org , Phone: 1-405-385-0354, Fax: 1-405-385-0357

INTRODUCTION

Distillation columns require packings and trays with low pressure drops and high performances, especially those intended for vacuum applications. Pressure drops across trays and packings are crucial factors for evaluating the performances of column internals. Pressure drop measurements also play an important role in the troubleshooting of distillation columns since misleading or incorrect measurements are among the top ten causes of column malfunctions⁽¹⁾. Using bubblers, one can also measure the liquid head inside liquid distributors, liquid holdups on tray decks, and downcomer backups etc.

Accurate and reproducible pressure drop measurements require careful designs of the measurement system including pressure taps, lines/tubings connecting to pressure transducers, locations of the tap and transducers, and calibrations etc. Various factors can affect the pressure drop measurements. The selection of pressure transducers, and calibrations are very first and important steps. It is not intended, however, in this paper to discuss pressure transducer selections and their calibrations. This paper will mainly discuss how to correctly measure, interpret and use pressure drop data. Causes of incorrect pressure drop measurements are discussed including the effects of column diameters, pressure tap sizes, locations, and vapor condensation etc. The effect of the static head of vapor on pressure drop data and column pressures is evaluated. Variations of sectional pressure drops along the column are investigated based on experimental data obtained from commercial size distillation columns at Fractionation Research, Inc. (FRI). As an example of the effect of pressure tap locations, the effect of the spacing between the liquid distributor and the top of the bed on the overall pressure drop measurements is discussed.

PRESSURE TAPS AND THEIR EFFECT ON PRESSURE DROP MEASUREMENTS

Column pressure drops are generally obtained using differential pressure transducers that measure the difference of static pressures at two locations. It is very critical to accurately measure those static pressures. To measure static pressure in a flowing vapor/liquid system, a wall static tap is usually utilized. The static pressure tap consists of a small hole drilled in the wall and connected to a pressure transducer via independent tubings. Errors in static pressure measurements caused by the taps directly affects column pressure drop data.

The static pressure is the pressure that would be measured with a probe moving with the flow. However, such a measurement is hard to make-without disturbing the flow. Since there is no static pressure variation normal to flow streamlines when those streamlines are straight, static pressure measurements can be taken using wall pressure taps in a region of the flow where streamlines are straight. Unfortunately, the presence of a hole in a wall may result in an inaccurate measurement due to the flow around the hole. **Figure 1**⁽²⁾ shows how the streamlines are deflected into the hole and eddies generated inside the hole. Those eddies are generally called cavity vortices. Due to the deflected streamlines

and eddies, static pressures measured by such taps could be higher than the “true” value

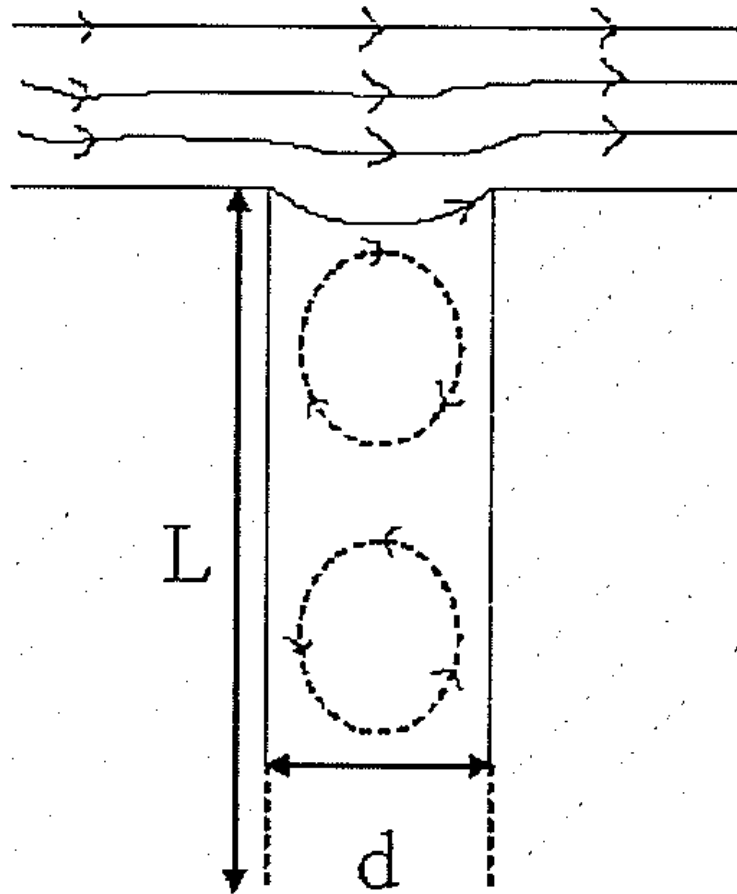

Figure 1. Flow Structure within the static pressure tapping

at the wall. It is expected that the error of static pressure would depend on the hole diameter d , the hole depth L (Figure 1), the diameter of the tubing connected to the pressure transducer d_c , the wall shear stress τ_w , the fluid density ρ , the dynamic viscosity μ , and column diameter D ,

$P_{s-error} = f(d, D, \tau_w, \rho, \mu, L, d_c)$. The effect of these parameters on static pressure is very complicated, and details can be found in papers published by various researchers^(3,4,5,6). As a practical guide, it is recommended⁽¹⁾ that the taps used for the static pressure measurement have following:

- (1) Large and constant L/d ratio, at least $L/d > 2$, to make sure that the flow within the cavity (tap) is fully developed
- (2) A small ratio of tap diameter to pipe/column diameter, to minimize the effect of the tapping on flow stream being studied
- (3) A wide cavity behind the tapping for taps with a small L/d ratio (< 2),

The second type of error will occurs if the static pressure tap is not flushed with the wall, or protruded into the column. This might happen, for example, if the pressure taps were mounted incorrectly, or if the surface of the column wall was eroding or ablating. The

protruded taps will disturb the boundary layer near the wall and result in error of static pressure measurement. The pressure obtained by the protruding tap is smaller than the “true” wall static pressure⁽⁷⁾. The larger the protruding length is, the bigger the error will be. Therefore, the protruded taps should be avoided for column pressure drop measurements.

EFFECT OF COLUMN DIAMETERS ON PRESSURE DROPS

Various studies^(8,9) show that the column size affects pressure drops across the packed bed. This effect is also packing dependent. For random packings, in small columns (less than 0.9 m), the smaller diameter column indicates lower bed pressure drop measurements. It is believed that this is likely due to the column wall effect. Compared to larger diameter columns, small columns have higher ratio of wall surface area to packing surface area. This may explain why the pressure drops with small column tend to be higher than large column. However, for structured packings, the effect of column size on pressure drops is the opposite. Limited data⁽⁸⁾ indicate that pressure drops measured from smaller column are higher than those from the larger columns. This may be caused by the relatively higher number of bends for vapor flow in a small column. Authors believe that wall-wipers with structured packings may also play a significant role of higher measured pressure drops in small columns. Since majority of the published pressure drop data were collected in pilot-scale columns/simulators, cautions need to be exercised to apply those data or correlations based on for commercial applications.

EFFECT OF VAPOR STATIC HEAD

Vapor Static Head and Column Pressure

The differential pressure between two locations in a distillation column has two components. They are static head due to the weight of the vapor between the two points and dynamic pressure drop due to the resistance of the internals to the flow. Most published pressure drop data were not corrected for the vapor static head, or have not mentioned whether the correction had been made or not.

The static head is usually insignificant in a trayed column as the minimum dynamic pressure drop for a tray is on the order of 25 mm H₂O/tray. However, the static head may cause serious errors/problems for a packed column, especially for low-pressure-drop packings. The following table shows comparison of dynamic pressure drop and static head for various systems commonly used by FRI:

System	Dynamic Pressure Drop	Static Head
	mm H ₂ O/m	mm H ₂ O/m
o/p xylene, 100 mmHg	0.8-70	0.5
Cyclohexane/n-heptane, 0.34 bar	1.7-45	1.1
Cyclohexane/n-heptane, 1.65 bar	4.0-85	5.0
Iso-butane/normal butane, 11.4 bar	1.0-50	29.0

Dynamic pressure drop in the table is the typical values for structured packings across the range of useful capacity. It may be observed from the table, as operations pressure increases, the static head becomes a significant portion of the dynamic pressure drops. For accurate pressure drop measurements, it is necessary to make static head correction when the values are reported just as it has been the FRI practice.

The column pressure is generally measured at the top of the column. The existence of static vapor head in the column and pressure drops will make the pressure at the bottom of the column significantly higher, especially for high pressure trayed columns. To calculate the column local pressure, the pressure drop and the static vapor head need to be added to the pressure measured at the top.

Vapor Static Correction and Inert Gas Purge

Figure 2 is a sketch of typical pressure drop set-up. As shown in figure, no static head correction would be required if both legs of pressure transducer would be filled by vapor in the column. However, in majority of distillation applications, the vapor condenses at ambient temperature. It is necessary to purge both legs with a non-condensable inert gas (usually nitrogen), so the static vapor head correction is needed in order to get the correct pressure drop readings.

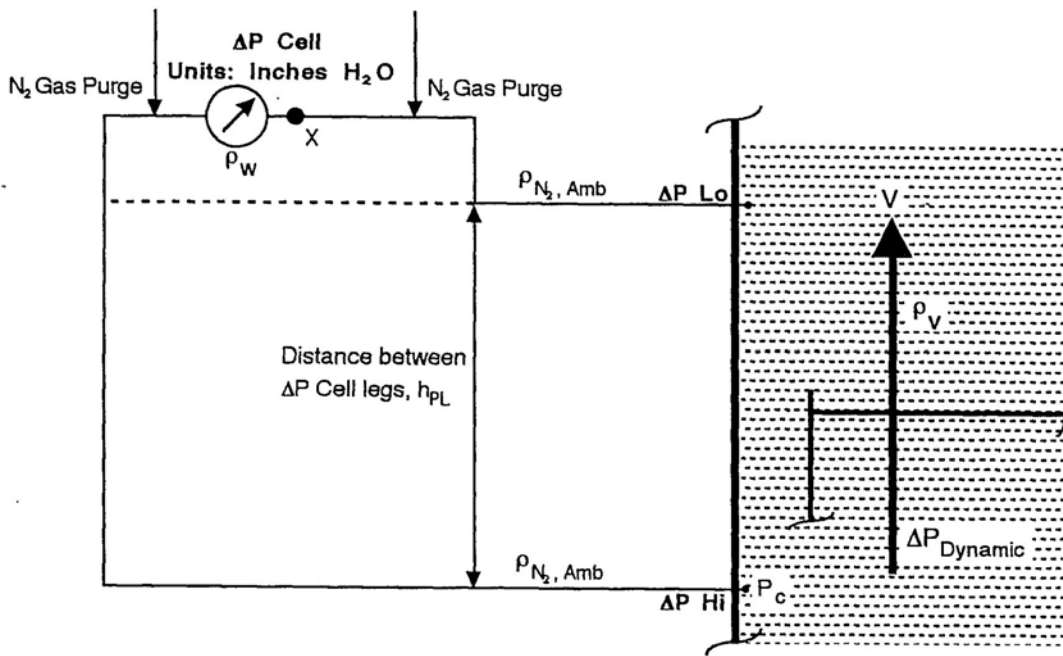

Figure 2. Column pressure drop measurement set-up

For a column set-up in **Figure 2**, the dynamic pressure drop in mm H₂O is given by:

$$\Delta P_{dynamic} = \text{Meter Reading (in mm H}_2\text{O)} - \left(\frac{\rho_V - \rho_{N_2, Amb}}{\rho_w} \right) h_{PL}$$

Where:

Meter reading = output of pressure transducer, mm H₂O

ρ_V = averaged vapor density over the section for pressure drop measurement

$\rho_{N_2, Amb}$ = density of N₂ gas at ambient pressure

ρ_w = density of water

h_{PL} = distance between two taps of pressure transducer

VARIATIONS OF SECTIONAL PRESSURE DROPS ALONG THE COLUMN

Pressure drops are a function of vapor and liquid loads, physical properties, and column internals. Due to composition changes along the column, the pressure drops at the top and bottom sections of the column could be very significantly different. **Figure 3** is a typical pressure drop data for structured packings with hydrocarbon system at vacuum conditions. As shown in the figure, the pressure drops at the bottom half of the column is significantly lower than the top half of the column, particularly at high vapor rates. In this case, the overall pressure drop data don't show the pressure drop variations along the column. This means that it may not be adequate to measure or monitor only overall pressure drops for a distillation column. For example, though the overall pressure drop measurement may not show that the column is close to the flood conditions, the sectional pressure drops of either the top half of the column or the bottom half of the column may indicate otherwise. It is recommended to measure/monitor the sectional pressure drops in addition to the overall pressure drops.

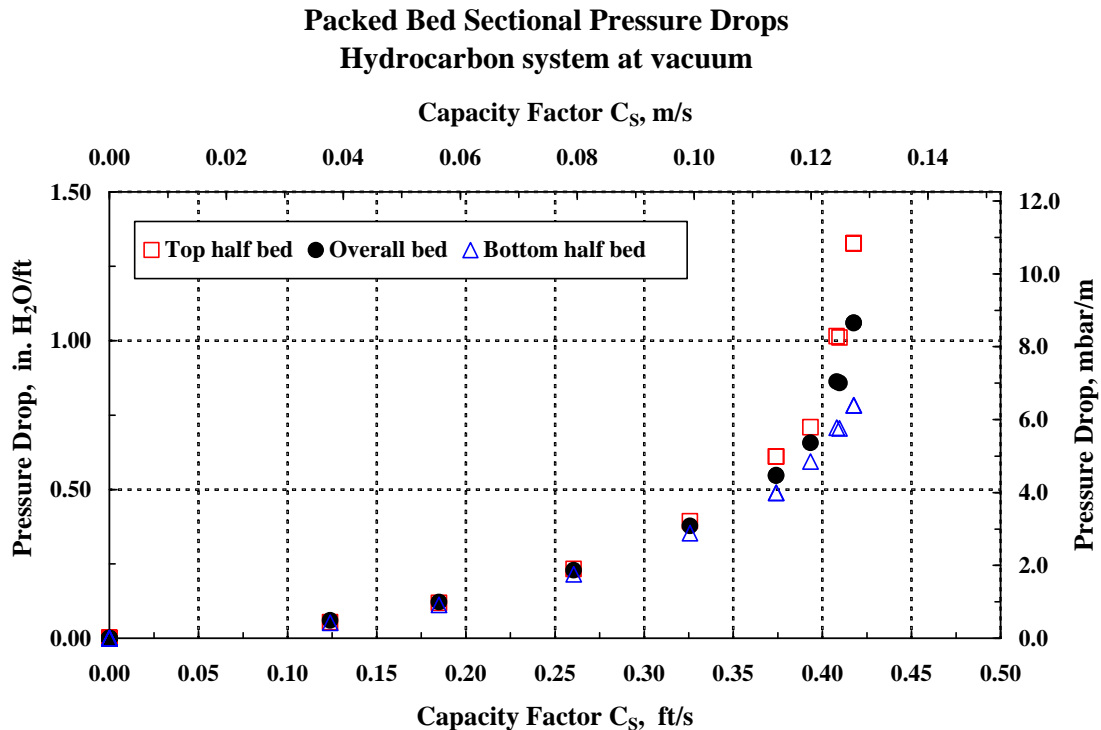

Figure 3. Sectional pressure drops of random packing at vacuum

EFFECT OF TAP LOCATIONS ON PRESSURE DROP

Placing pressure taps at right locations are very critical to obtain accurate and reliable pressure drop measurements. Column pressure taps must be located where there is no danger of submergence below a liquid level in the column. Pressure taps should be placed not too close to the vapor inlets or outlets as inlet/outlet alters the local velocity profile and affects the static pressure locally. If the tap has to be placed close to the inlet, it is preferred to be installed along the same side of the inlet. For outlet, the tap needs to be positioned at the opposite side of the pressure tap to minimize the impact of vapor outlet on pressure drop measurements.

For majority of distillation applications, vapor condenses inside the tubing connected to the pressure transducer at ambient temperature. It is important to make sure that any vapor condensation in the line flows back to the column without affecting the pressure drop measurements. If practical, all pressure taps need to be placed below the pressure transducer. It is suggested that inert gas, for example nitrogen, be used to purge the lines independently. In the FRI experimental unit, all pressure transducers are located at the top deck, and all lines connecting to pressure transducers are purged independently using nitrogen to make sure no vapor condensation inside the line.

Any changes in the local flow profiles will affect the static pressure. If pressure taps are placed at locations with very different local vapor profile, the measured pressure drops need to be corrected according to the vapor velocity changes. Column diameter changes, vapor side-draw, and hardware below or above the pressure taps etc all will affect the local flow profile. As a case study, the following section shows how the placement of a liquid distributor above the pressure tap affects the pressure drop measurements.

Effect of Liquid Distributor Placement on Packed Bed Pressure Drop

Figure 4 is a schematic diagram of the bed pressure drop measurement set-up in a typical distillation column. The bed pressure drop is measured with differential pressure transducers. Each pressure transducer has its own independent leg and column connection. The legs are continuously purged with a constant flow of nitrogen. As shown in **Figure 4** the high pressure leg, installed just below the packing support plate, measures the bottom static pressure P_{SB} ; and low pressure leg, installed between the distributor and the top of the packed bed, measures the top static pressure P_{ST} . In general, when the column is near flooding condition, froth will very likely be generated on the top of the bed. To avoid the effect of the froth on the pressure measurement, the low pressure leg is usually installed about 76.2-127.0 mm above the top of the bed. The differential pressure of P_{SB} and P_{ST} , $\Delta P = P_{SB} - P_{ST}$, is the measured packed bed pressure drop.

The vapor velocity prior to entering the packed bed is the same as the superficial vapor velocity V_S as shown in **Figure 4**. Because of low liquid holdup before approaching flood and large void fraction of both the structured and random packings, the averaged vapor velocity in the packed bed is approximately equal to the superficial vapor

velocity V_s . The vapor velocity exiting the top of the packed bed is about the same as superficial velocity V_s . Assuming the open area of the liquid distributor is about 14.5 per cent of the column cross sectional area, the averaged vapor velocity around the distributor

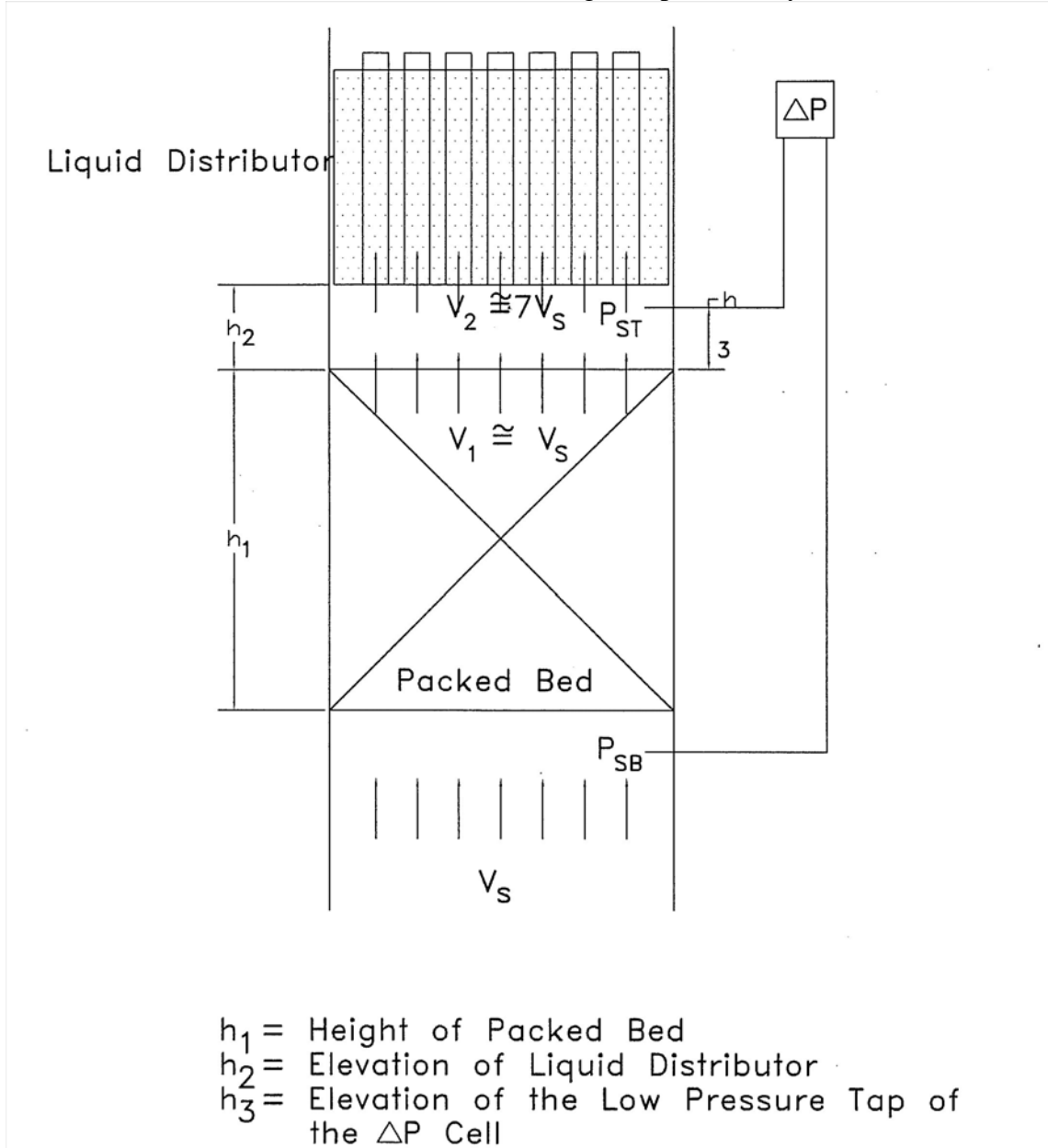

Figure 4. Pressure drop measurement set-up across the packed bed

will be about seven times the exiting vapor velocity from the top of the packed bed. In other words, the vapor accelerates dramatically after it exits from the packed bed. The vapor velocity around the low pressure leg will be much higher than the superficial vapor velocity V_s due to the vapor acceleration. It is known from fundamental fluid dynamics that the vapor acceleration will cause a decrease of the static pressure around the low pressure leg. Therefore, the measured static pressure at the low pressure leg will be lower

than the actual static pressure. So the measured packed bed pressure drop, $\Delta P = P_{SB} - P_{ST}$, will be higher than the actual packed bed pressure drop.

It is obvious that the actual vapor velocity around the low pressure leg strongly depends on the spacing between the top of the bed and the liquid distributor. The smaller the spacing is, the higher the vapor velocity around the leg will be. The vapor flow between the packed bed and the liquid distributor is a very complicated phenomenon. It is a severely constricted flow, due to the sudden change of the opening flow area and the countercurrent liquid flow between the top of the packing and the bottom of the liquid distributor.. It is not attempted in this report to obtain the actual vapor flow distribution between the top of the packed bed and the liquid distributor. This is beyond the scope of this study. To illustrate the effect of the spacing on the averaged vapor velocity around the low pressure leg, it is assumed that the vapor flow has a parabolic distribution. **Figure 5** shows the vapor velocity distribution between the top of the bed and liquid distributor for three different liquid distributor placements, 152.4, 304.8 and 457.2 mm above the top of the bed. As indicated in this figure the local velocity is a strong function of the spacing. The 152.4 mm spacing has the largest velocity gradient, and the 457.2 mm spacing the smallest velocity gradient. 152.4 mm spacing is a very typical distance for distillation applications, given the low pressure leg installed 101.6 mm above the top of the bed, the vapor velocity around the leg is about 3.7 times the superficial velocity V_s .

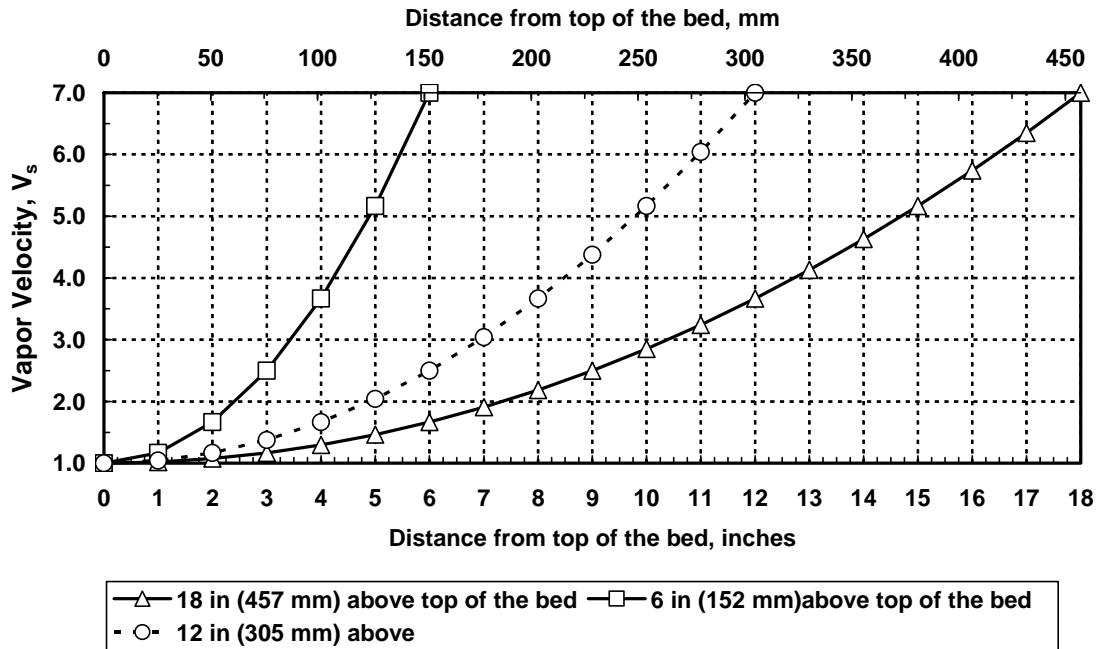

Figure 5. Vapor velocity profile vs distance from top of the bed
(Illustration only)

Table below shows an actual case study for a random packing test with the C₆/C₇ system at 1.65 bar. In this test the low pressure leg was installed 120.7 mm above the top of the packed bed. The local vapor velocity around the low pressure leg was 4.76 times the superficial velocity V_s. Since the superficial vapor velocity of this run was 3.20 ft/s (0.97 m/s), the local vapor velocity around the leg was 15.22 ft/s (4.64 m/s). The pressure difference ΔP_c caused by the vapor acceleration is about 0.220 in H₂O (0.55 mbar). The measured pressure drop of the top half of the packed bed is 2.74 in H₂O (6.82 mbar). Therefore, the measured pressure drop of the top of the bed is about 8.72 per cent higher than the actual bed pressure drop due to the vapor acceleration around the low pressure leg.

Random Packing				
System	C ₆ /C ₇			
Column pressure	24	psia	1.65	bar
Vapor density	0.332	lb/ft ³	5.32	kg/m ³
Liquid density	39.32	lb/ft ³	629.9	kg/m ³
Capacity factor, C _s	0.295	ft/s	0.090	m/sec
Superficial velocity, V _s	3.197	ft/s	0.974	m/sec
Elevation Low leg of ΔP cell	4-3/4	inch	120.65	mm
Measured top half bed ΔP	2.74	in H ₂ O	6.81	mbar
Spacing between the top of the bed and liquid distributor	6	inch	152.4	mm
ΔP_c due to vapor acceleration	0.220	in H ₂ O	0.55	mbar
Relative difference	8.72	%		

DISCUSSION AND CONCLUSIONS

The size, shape and locations of pressure taps have a significant effect on the accuracy and consistency of the pressure drop measurements. Vapor static head needs to be subtracted from total differential pressure in order to obtain the actual dynamic pressure drops. On the other hand, the static head should be added to get the correct pressure at different column locations. Due to composition variations along the column, the pressure drops at the top and bottom sections of the column could be very significantly different. Flow profile changes due to column diameter change or hardware inside the column may alter the local static pressure. This alteration needs to be accounted for and corrected in pressure drop results.

REFERENCE

1. H.Z. Kister, Distillation Troubleshooting, Wiley-Interscience, Hoboken, New Jersey, 2005
2. B.J. Mckeon and A.J. Smith (2002), Measurement Science Technology, 13, 1608-1614 482-486.
3. R. Shaw (1960), The influence of hole dimensions on static pressure measurements, J. Fluid Mech., 7, 550-564
4. R.E. Franklin and J.M. Wallace (1970), Absolute measurements of static-hole error using flush transducers, J. Fluid Mech., 42, 33-48
5. S.H. Chue (1975), Pressure probes for fluid measurement, Prog. Aerosp. Sci., 16, 147-223
6. C. Ducruet and Dymont (1984), The pressure-hole problem, J. Fluid Mech., 142 251-267
7. H. Zogg and H. Thomann (1972), Errors in static measurements due to protruding pressure taps, J. Fluid Mech., 54, part3, 489-494
8. Z. Olujić (1999), Effect of column diameter on pressure drop of corrugated sheet structured packing, Trans. IChemE 77, 505-510
9. R. Billet, Distillation Engineering, Chemical Publishing Co., New York, 1979